

FLANGED TEMPERATURE SENSORS



VNG H: Thermocouple type

Description:

Thermocouple sensor, **DN40/PN40** flanged mounting with neck (length of neck=**50 mm**) with connection head, for temperature measuring of fluent and gaseous agents.

Temperature: „J” 0...750°C, „K” 0...1100°C, „S” 0...1300°C, „R” 0...1400°C, „B” 0...1800°C

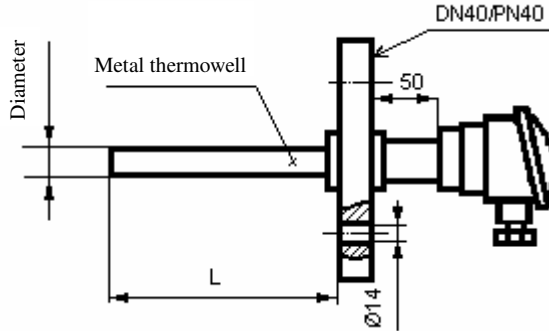

Ordering code: MEASURING-ELEMENT:

Thermocouple type: (Fe-CuNi) J
(NiCr-Ni) K
(PtRh90/10-Pt) S
(PtRh87/13-Pt) R
(PtRh70/30-PTRh94/6) B
Other 9

Class of accuracy: (J, K, S, R) I.
(B) II.

Diameter of thermocouple-wire (mm):
(J, K) 3,0
(J, K) 1,0
(S, B) 0,5
(S, R) 0,35
Other 9

Construction: simple
double

THERMOWELL:

Material of thermowell: 1.4301
1.4541
1.4571
Other

Diameter of thermowell [mm]: 13,5
15,0
16,0
18,0
20,0
22,0
Other

Length of thermowell: L [mm]:

V	N	G	H							
J	K	S	R	B	9					
1	2									
3	1	0,5	0,35	9						
1	2									
1	2	3	9							
1	3	5								
1	5									
1	6									
1	8									
2	0									
2	2									
9										

Naturally, we can differ from the above construction.

Please, fill in the ordering code and send your enquiry (order) to us.

fax: 00-36-1-282-6135, e-mail: ugyfelsz@rhodium.hu, We will discuss the details.

If you have question, please call: 00-36-1-282-5689 and 00-36-1-282-8308, Our customer service is available.